



SPHEROS

WEBASTO BUS PRODUCTS

Klimaanlage

A/C unit

Ersatzteil-Liste

Spare parts list

Aerosphere Midibus

06/2006

Id-Nr. 11 037 43A

Aerosphere Midibus

Bild/fig. 1

**Klima-Verflüssigereinheit
A/C condenser unit**

Bild/fig. 2-4

HINWEIS:

„S“ vor der Bestell-/Ident-Nr. bedeutet:
Lieferzeit kann bis zu 6 Wochen betragen.

- Spalte A/N: Damit zur Vorgängerausgabe ersichtlich wird, welche Teile geändert und neu hinzugekommen sind, werden sie hier angezeigt mit:
A = Änderung N = Neuteil
- Spalte Benennung: Nach rechts eingerückte Teile bzw. Untergruppen (durch Punkte markiert) sind in den um einen Punkt weniger eingerückten Baugruppen enthalten.
- Beispiel:
Brennstoffpumpe = Hauptgruppe
• Magnetventil = Untergruppe von Hauptgruppe
• • Runddichtring = Einzelteil von Untergruppe
- Column A/N: Indicates which parts are modified, which parts are new:
A = modification N = new part
- Column Description: Sub-assemblies or components (marked by a point) - offset to the right - are contained in the assembly which is offset one point less.
- Example:
fuel pump = assembly
• solenoid valve = sub-assembly
• • gasket = component

Änderungen vorbehalten / Subject to modification

Pos. Item	Stück Quantity						Bestell-Nr. Part no.	A / N	Benennung	Description	Bemerkung Remark
	18kW	18kW	14kW	18kW	18kW	18kW					
Aerosphere Midibus											
1	1						11 023 50B		Aerosphere Midibus	Aerosphere Midibus	18kW Wabco, R=18.000 3 Verflüssigergebläse 4 Verdampfergebläse / 3 condenser fans 4 evaporator fans
2		1					11 029 29B		Aerosphere Midibus	Aerosphere Midibus	18kW Globus, R=18.000 3 Verflüssigergebläse 4 Verdampfergebläse / 3 condenser fans 4 evaporator fanst
3			1				11 026 85B		Aerosphere Midibus	Aerosphere Midibus	14kW Globus, R=18.000 2 Verflüssigergebläse 4 Verdampfergebläse / 2 condenser fans 4 evaporator fans
4				1			11 034 70A		Aerosphere Midibus	Aerosphere Midibus	18kW Wabco, R=6.000 3 Verflüssigergebläse 4 Verdampfergebläse / 3 condenser fans 4 evaporator fans
5					1		11 035 11A		Aerosphere Midibus	Aerosphere Midibus	18kW Globus, R=6.000 3 Verflüssigergebläse 4 Verdampfergebläse / 3 condenser fans 4 evaporator fans
6						1	11 035 12a		Aerosphere Midibus	Aerosphere Midibus	14kW Globus, R=6.000 2 Verflüssigergebläse 4 Verdampfergebläse / 2 condenser fans 4 evaporator fans

Aerosphere World / Midibus - fig. 1

1, 2, 4, 5

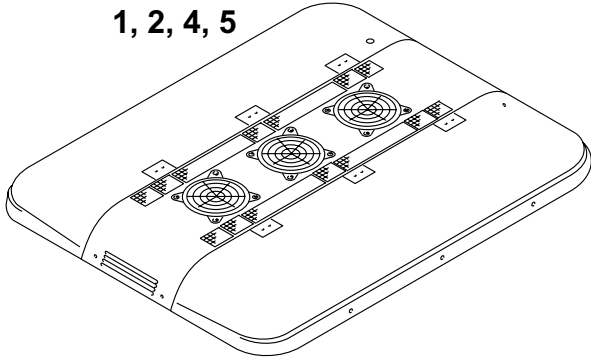

3, 6

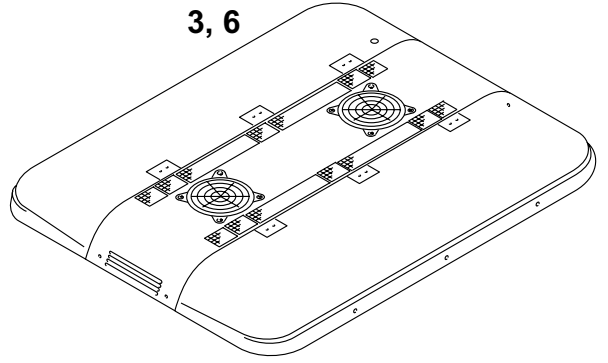

Pos. Item	Stück Quantity						Bestell-Nr. Part no.	A / N	Benennung	Description	Bemerkung Remark
	.. 50B	.. 29B	.. 85B	.. 70A	.. 11A	.. 12A					
Klima-Verflüssigereinheit / A/C condenser unit											
1	1	1	1	1	1	1	11 024 09B		Haube li	hood LH	
2	1	1	1	1	1	1	11 024 10B		Haube re	hood RH	
3	1	1					11 023 90C		Abdeckblech Verflüssiger	condenser cover	18kW; R=18.000
3			1				11 026 84A		Abdeckblech Verflüssiger	condenser cover	14kW; R=18.000
3				1	1		11 034 71A		Abdeckblech Verflüssiger	condenser cover	18kW; R=6.000
3						1	11 035 28A		Abdeckblech Verflüssiger	condenser cover	14kW; R=6.000
4	6	6	6	6	6	6	11 023 91C		Scharnier	hinge	
5	6	6	6	6	6	6	11 025 24B		Scharnierdeckel	hinge cover	
6	6	6	6	6	6	6	11 024 08B		Dichtplatte Scharnier	hinge sealing	
7	3	3	2	3	3	2	11 027 41A		Axialgebläse	axial fan	
8	3	3	2	3	3	2	680 55A		Schutzgitter	protective screen	
9	2,8 m	2,8 m	2,8 m	2,8 m	2,8 m	2,8 m	926 93B		Dichtprofil	rubber seal	Meterware / per meter Haube / hood
10	1 m	1 m	1 m	1 m	1 m	1 m	11 001 46A		Kantenschutz- Dichtprofil	edge protector	Meterware / per meter
11	1	1	1	1	1	1	11 024 84B		Halter Abdeckblech li	support cover LH	
12	1	1	1	1	1	1	11 024 85B		Halter Abdeckblech re	support cover RH	
13	6	6	6	6	6	6	11 024 11B		Halter Haubenschluss	support cover lock	
14	6	6	6	6	6	6	800 38B		Klemmmutter M6	clamping nut	
15	6	6	6	6	6	6	900 49A		Linsenschraube	oval head screw	
16	6	6	6	6	6	6	900 47B		Scheibe	washer	
17	6	6	6	6	6	6	483 80A		Unterleggummi	rubber seal	

Aerosphere World / Midibus - fig. 2

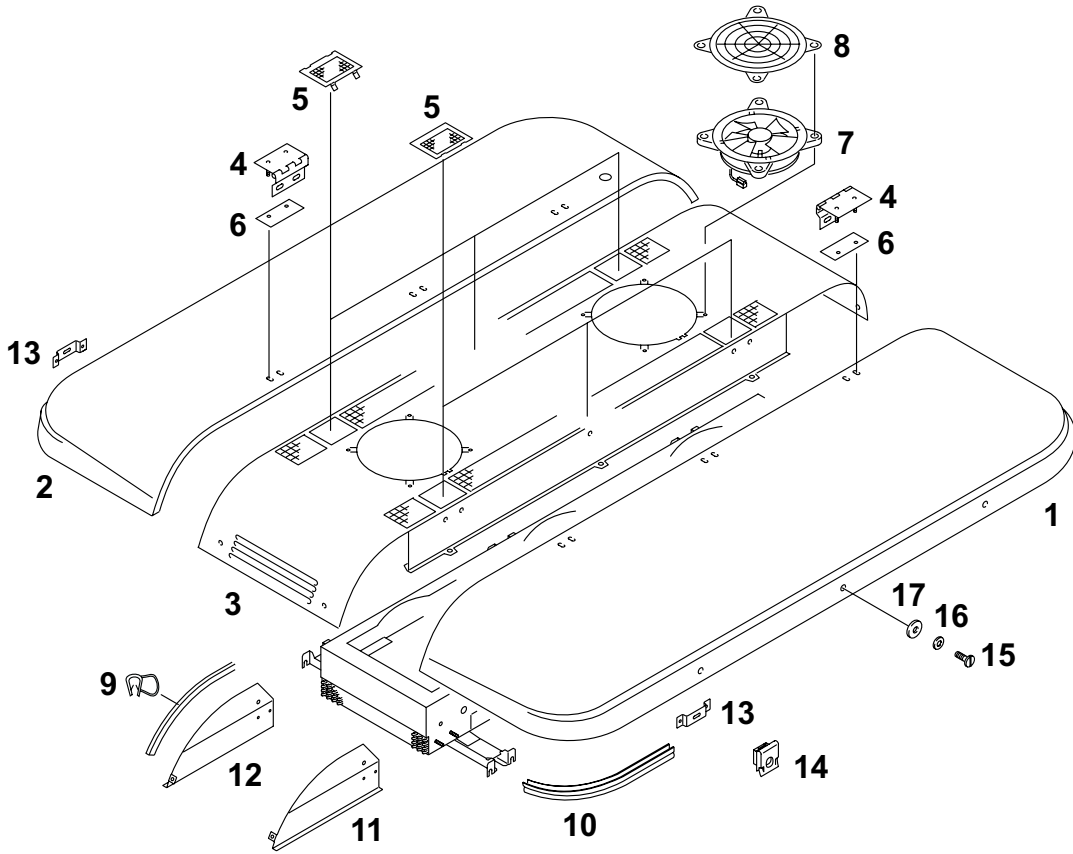

Pos. Item	Stück Quantity						Bestell-Nr. Part no.	A / N	Benennung	Description	Bemerkung Remark
	.. 50B	.. 29B	.. 85B	.. 70A	.. 11A	.. 12A					
Klima-Verflüssigereinheit / A/C condenser unit											
1	1	1					11 023 72A	Verflüssigereinheit	condenser unit	18kW; R=18.000 vormontiert pre-assembled	
1			1				11 027 04B	Verflüssigereinheit	condenser unit	14kW; R=18.000 vormontiert pre-assembled	
1				1	1		11 035 10A	Verflüssigereinheit	condenser unit	18kW; R=6.000 vormontiert pre-assembled	
1						1	11 035 26A	Verflüssigereinheit	condenser unit	14kW; R=6.000 vormontiert pre-assembled	
2	4,2 m	4,2 m	4,2 m	4,2 m	4,2 m	4,2 m	11 027 36A	Dichtprofil	rubber seal	Meterware / per meter Wanne / vat	
3	1	1	1	1	1	1	11 023 79B	Verdampfer / Heizteil li	evaporator / heating element LH		
4	1	1	1	1	1	1	11 023 86B	Verdampfer / Heizteil re	evaporator / heating element RH		
5	4			4			11 017 83A	Gebälse	fan	ebm K3G 097	
5		4	4		4	4	915 24B	Gebälse	fan	Spal 009-B40	
6	8	8	8	8	8	8	11 020 26A	Spannklammer	clamp		
7	2	2	2	2	2	2	11 023 55A	Luftklappe Zsb.	air flap assy		
8	2	2	2	2	2	2	928 86A	Stellmotor	motor		
9	6	6	6	6	6	6	929 30B	Distanzbuchse	spacer		
10	2	2	2	2	2	2	926 09A	Klappenlager	flap bearing		
11	1			1			11 025 25E	Kabelbaum li / re	wiring harness LH /RH	Wabco	
11		1	1		1	1	11 027 22D	Kabelbaum li / re	wiring harness LH /RH	Globus	
12	1	1	1	1	1	1	11 025 33A	Kabelbaum	wiring harness	Verflüssiger / condenser	
13	2	2	2	2	2	2	11 020 13A	Zahnrad	toothed wheel	für Luftklappe / for air flap	
14	2	2	2	2	2	2	11 020 50A	Silikonöldämpfer	silicon oil damper		
15	1			1			831 86A	Eissensor	ice sensor	Wabco	
16	1			1			11 007 33A	Anlaufmodul	starting module	PWM3-2GB	
17	1			1			11 005 15A	Anlaufmodul	starting module	PWM3-1GB	
18	1			1			831 64A	Temperatursensor	temperature sensor	Wabco	
19	1			1			680 12A	Unterstation	control sub-unit		
20	4	4	4	4	4	4	11 025 74A	Luftfilter	air filter		
21		1	1		1	1	11 017 42A	Relaistafel kpl.	relay board assy	Globus	
22		1	1		1	1	11 017 44A	Heizungssteuerung	contol unit heater	Globus	
23		1	1		1	1	11 037 41A	Klappensteuerung	contol unit flaps	Globus	
24		5	5		5	5	11 037 42A	Relais Gebläse	relay fan	Globus	
25											
26		1	1		1	1	11 030 40A	Raumfühler	room sensor	Globus	
27		1	1		1	1	11 030 41A	Außenfühler	outer sensor	Globus	
28		1	1		1	1	317 38A	Vereisungsschutz	anti-icing thermostat	Globus	

Aerosphere World / Midibus - fig. 3

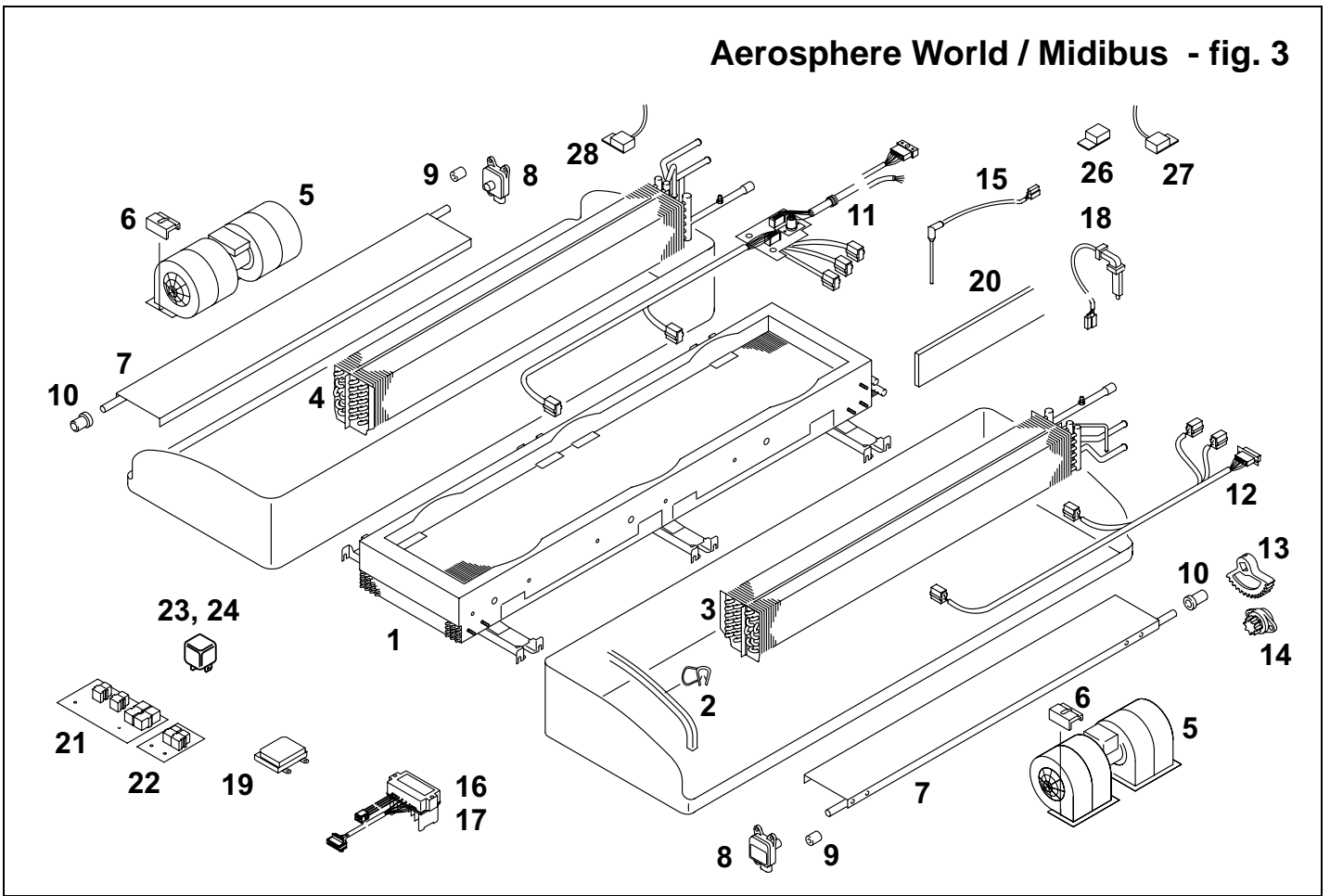

Pos. Item	Stück Quantity						Bestell-Nr. Part no.	A / N	Benennung	Description	Bemerkung Remark
	.. 50B	.. 29B	.. 85B	.. 70A	.. 11A	.. 12A					
Klima-Verflüssigereinheit / A/C condenser unit											
1	1	1	1	1	1	1	935 10B		Kältemittelmagnetventil	refrigerant solenoid valve	
2	1	1	1	1	1	1	11 026 20A		Spule	coil	für Kältemittelmagnetventil / for solenoid valve
3	1	1	1	1	1	1	11 02081A		Eckabsperrentil	check valve	
4	1	1	1	1	1	1	11 024 99A		Sammler	receiver	
5	1	1	1	1	1	1	11 019 72A		Filtertrockner	filter drier	7/8" UNF / O-Ring
6	1	1	1	1	1	1	11 019 73A		Schauglas	sight glass	7/8" UNF / O-Ring
7	3	3	3	3	3	3	11 020 51A		O-Ring	o-ring	7/8"
8	2	2	2	2	2	2	11 003 95A		Expansionsventil	expansion valve	
9	1	1	1	1	1	1	11 009 51A		Sicherheitsventil	safety valve	
10	4	4	4	4	4	4	11 00585A		Verbindungsrohr	connection tube	
11	2	2	2	2	2	2	11 029 40A		Wasserschlauch	water hose	
12	8	8	8	8	8	8	11 026 48A		Distanzscheibe	spacer	D=25; M8
13		1	1		1	1	11 030 42A		Ausblasfühler	air flow sensor	Globus im Luftkanal des Fahrzeuges eingebaut / mounted in air duct of the vehicle
14	1			1			929 31B		Druckschalter	pressure switch	G 63

Aerosphere World / Midibus - fig. 4

